



Acho Dene Koe First Nation/Borealis Geothermal Energy Project

Appendix C

Process

FORT LIARD GEOTHERMAL PROJECT PROCESS FLOW DIAGRAM

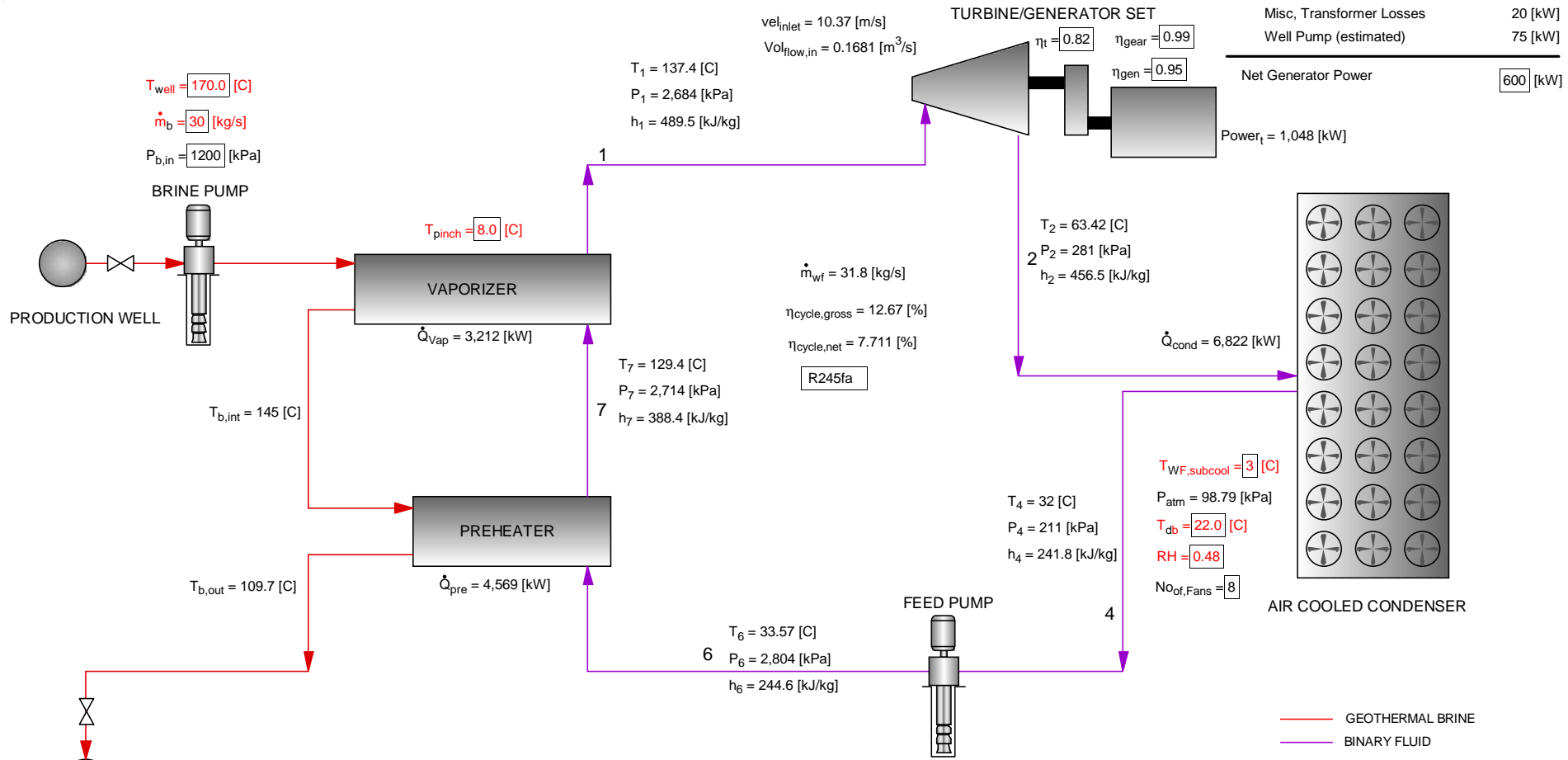

Gross Generator Power	986 [kW]
Parasitic Loads	
Feed Pump	97 [kW]
ACC Fans	184 [kW]
Aux Cooling and Lube Oil System	10 [kW]
Misc, Transformer Losses	20 [kW]
Well Pump (estimated)	75 [kW]
Net Generator Power	600 [kW]

